

Stainless Steel Horizontal Multistage Pump — SHM(T)20

Performance Curves

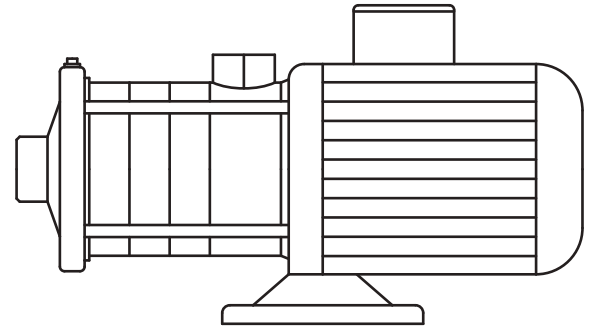

SHM/SHMT

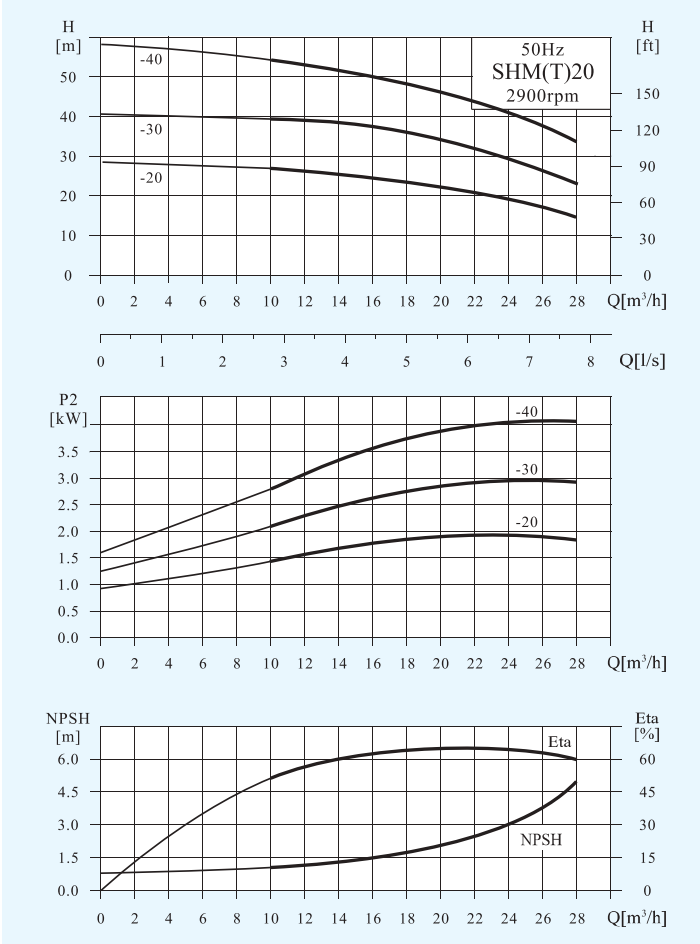
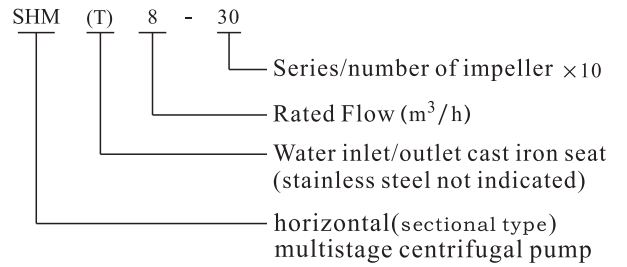

Dimension & Weight

Motor	Specification (mm)												Net Weight (kg)
	L	L1	L2	L3	L4	L5	L6	Hthree phase	Hsingle phase	H1	H2	D	
SHM(T)20-20	455	138	151	126	160	108	130	240	270	118	228	180	27
SHM(T)20-30	576	140	294	171	170	190	230	270		120	230	220	40
SHM(T)20-40	621	140	340	216	170	190	230	270		120	230	220	44

Stainless Steel Horizontal Multistage Pump — SHM(T)20

Structure chart:SHM

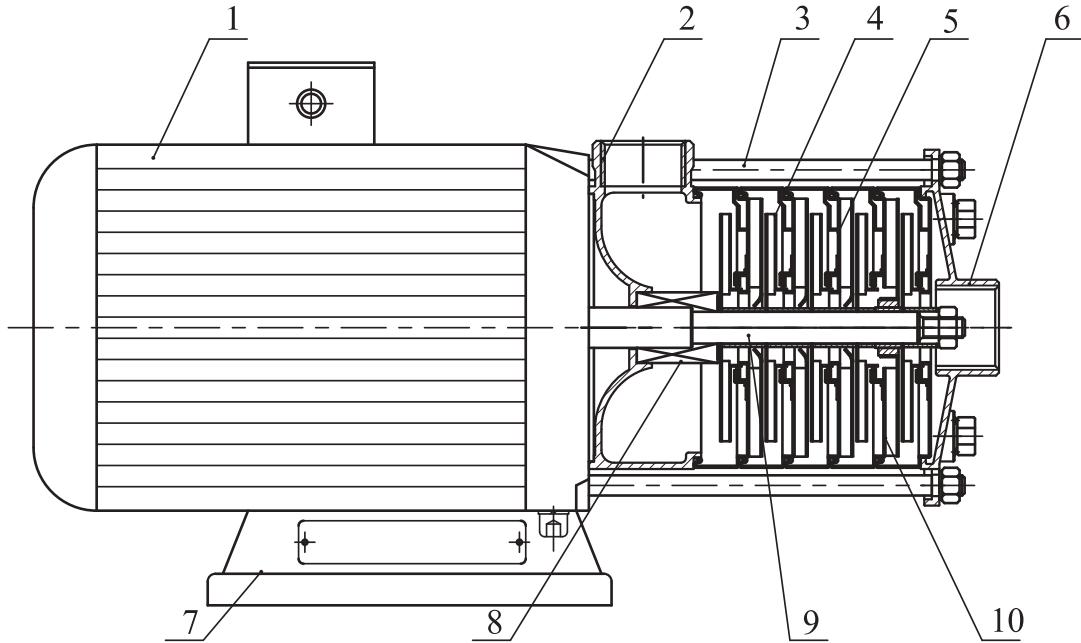

Material:SHM

NO	Description	Material	AISI/ASTM	NO	Description	Material	AISI/ASTM
1	Motor	Assembling unit		6	Inlet seat	Stainless	AISI304
2	Outlet seat	Stainless steel	AISI304	7	Base plate	Steel	AISI11015
3	Tie rod	Stainless steel	AISI304	8	Mechanical seal	Assembling unit	
4	Impeller	Stainless steel	AISI304	9	Shaft	Stainless	AISI304
5	Diffuser	Stainless steel	AISI304	10	Support diffuser.	Stainless	AISI304